

### Part III: Controls, Functions and Components

In the box you should receive:

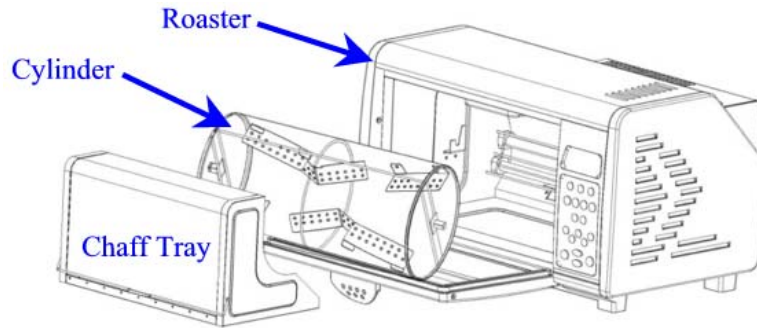

and brush (not pictured)

#### Basic Functions and System Components:

##### Control Panel:

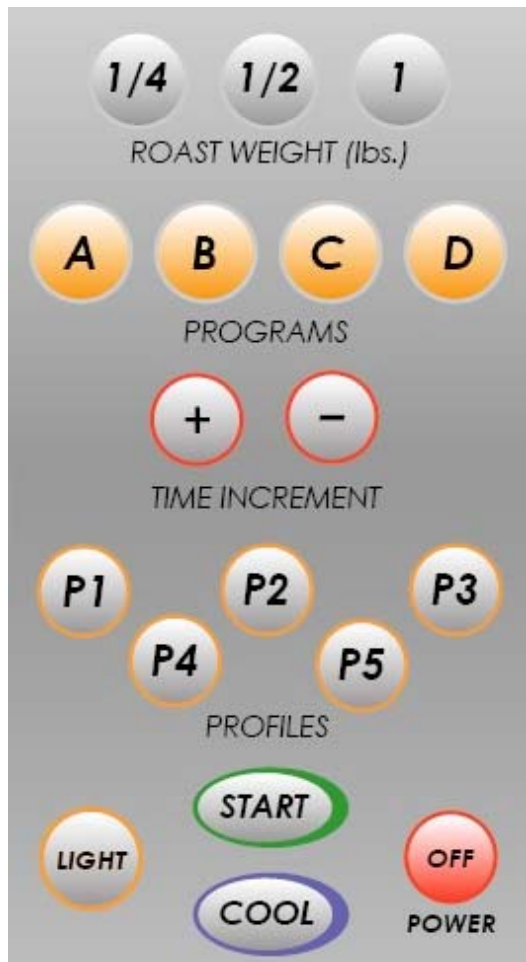

**Roast Weights:** Weight of green coffee beans to be roasted and system on switch. The weight buttons also act as default settings, allowing the user to “reset” the program at anytime before pressing start.

**Programs/Times:** System roast times directly associated with the weight chosen. See Tips and Maintenance for more complete information related to these examples.

**Time Increments:** Add or subtract time to/from the roast programs prior to start or at any point during roast cycle. Pressing “+” adds 15 seconds, “-” subtracts 10 seconds.

**Profiles:** Denote how heat is applied to the beans. P1 is the highest heat application, thus fastest roast time. P5 is the lowest overall heat application, thus slowest roast time. See Diagram of Profiles for details on heat applications along with Tips Section for more details.

**Start:** Starts the roasting cycle.

**Cool:** Allows the user to stop a roast at any time and begin cooling the beans,

**Light:** Light switch for viewing beans

**Off:** Ceases all system functions. DO NOT press OFF during the roast cycle **except** in an emergency situation (such as fire). Pressing OFF before the roast cycle is complete could lead to excessive smoke and possibly create a fire hazard.

### Part III: Controls, Functions and Components Continued

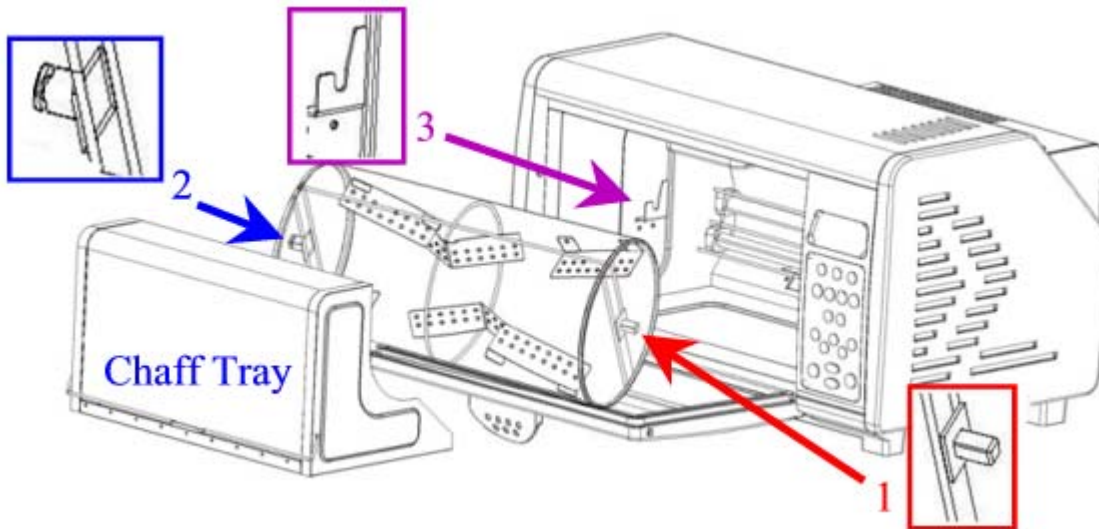

**Cylinder:** The cylinder (see above) has been designed for ease of use. One end has a square peg (red arrow- #1), which can only fit into the motor drive (inside right-not shown), with the left end having a grooved round peg (blue arrow- #2) whose groove drops into the holder's (purple arrow- #3) slot. The standard cylinder that ships with the roaster is not designed for use with small bean types such as Ethiopian, Yemeni or blends containing either. A separate cylinder w/ smaller grid is available through your retailer for use with those bean types or blends

**Chaff Tray:** Collects chaff that falls from the cylinder and pushed into the tray by the cooling fan. Once the beans have finished a complete cycle of both roasting and cooling, open the door. The majority of the chaff should be in the tray. The tray can then be used as a "dust pan". Remove the tray; remove the cylinder, then using the brush sweep the remaining chaff into a pile. Place the tray at the lip of the roasting chamber and using the brush, sweep the remaining chaff into the tray.

**Roast Cycle:** The system has been designed to read the data input (weight, time, etc.) and adjust system functions accordingly. The initial start times are the basis for the Profiles but times can be adjusted up (+ equals 15 seconds added) or down (- equals 10 seconds subtracted) at any time prior to start or during the roast. When the roast time has reached 59 seconds remaining, the digital display will blink on and off alerting you to time remaining until roast completion. If you desire to add time, you can do so up until a display time of 00:01. If you allow the system to go to 00:00, it will automatically go into its pre-programmed cooling cycle. WHEN THE SYSTEM GOES INTO COOLING DO NOT RESTART THE ROAST CYCLE. DOING SO WILL CREATE TREMENDOUS AMOUNTS OF SMOKE AND POSSIBLY CREATE OTHER HAZARDS.

**Cooling Cycle:** The system has two cooling cycle programs. One is an automatic cooling cycle that starts once the roasting timer goes to 00:00. When cooling begins, the display will show the countdown time for cooling. There is also a manual cooling cycle option available to the user. Should you decide at any time to end a roast, simply press the cool button and roasting will cease and cooling will begin. As with automatic cooling, the system timer will reset and show a new countdown for the cooling cycle.

**Each system's function has been designed for a reason. It is imperative you allow the system to perform as designed for optimal performance and longevity. This is especially true of the cooling cycle. Failure to comply with these recommendations or those listed in the Important Safeguards could result in a potential safety hazard.**

**If you do not understand a function or parts of the system, email us at [tech@behmor.com](mailto:tech@behmor.com) and we will do our best to answer any/all questions you might have. Please include a phone number so we can, if necessary call to better communicate an answer to you.**

---